

6 Transport

Contents

6.1	Scope of delivery	3
6.2	Packing	3
6.3	Degree of disassembly	3
6.4	Susceptibility	3
6.5	Preparing for transport	4
6.6	Accidents during transportation	4
6.7	Storage	4
6.8	Weights and points of attachment	5
6.9	Instructions for lifting	5
6.9.1	Machine base	6
6.9.2	Closing unit	7
6.9.3	Closing unit with machine base	8
6.9.4	Drive unit	9
6.9.5	Injection unit	10
6.9.6	Control cabinet	11

Software
Page Maker 6.5

6.1 Scope of delivery

The contents of each package as stated on the delivery note, should be checked for completeness upon receipt.

Any damage from transportation or missing parts are to be notified immediately inwriting.

6.2 Packing

Deciding for the kind of packing is also the carrying distance. If not specifically agreed otherwise, the packing is conform to recommendations for packaging. Depending on the place of delivery the machine parts are shipped open or partially packed. The packing material should be disposed of in accordance with the local regulations.

6.3 Degree of disassembly

The degree to which the machine is disassembled for transport depends on the transport provisions, the local conditions and the lifting gear available.

It is aimed at to transport the DCM as much as possible in one piece.

Usually the DCM is taken apart into following sections:

6.4 Susceptibility

During transportation of the DCM or DCI particular care must be taken to avoid damage through force from outside or careless loading or unloading.

Please take notice of the following symbols on the packing.

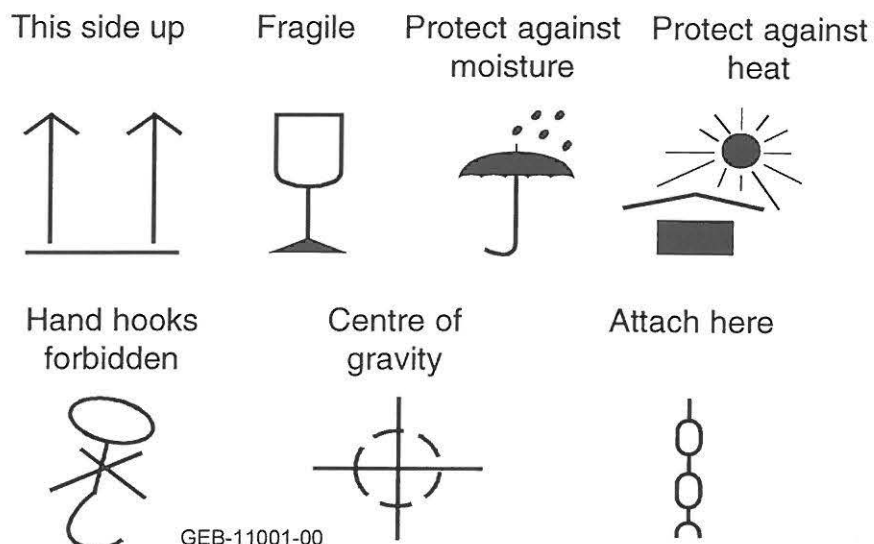

6.5 Preparing for transport

Before moving or transporting the DCM inside the factory:

- empty the nitrogen system
- empty the hydraulics tanks (closing and injection unit)
- tighten the transport securing bolts.

Transport the DCM according to instructions for lifting.

6.6 Accidents during transportation

In the event of an accident during transport please inform our customer service immediately.

6.7 Storage

Leave the DCM or DCI in its original packing for storage and place it where it is protected against the influence of weather.

If this is not possible the machine or installation sections and boxes should be:

- properly covered
- protected against intensive exposure to sun
- protected against moisture

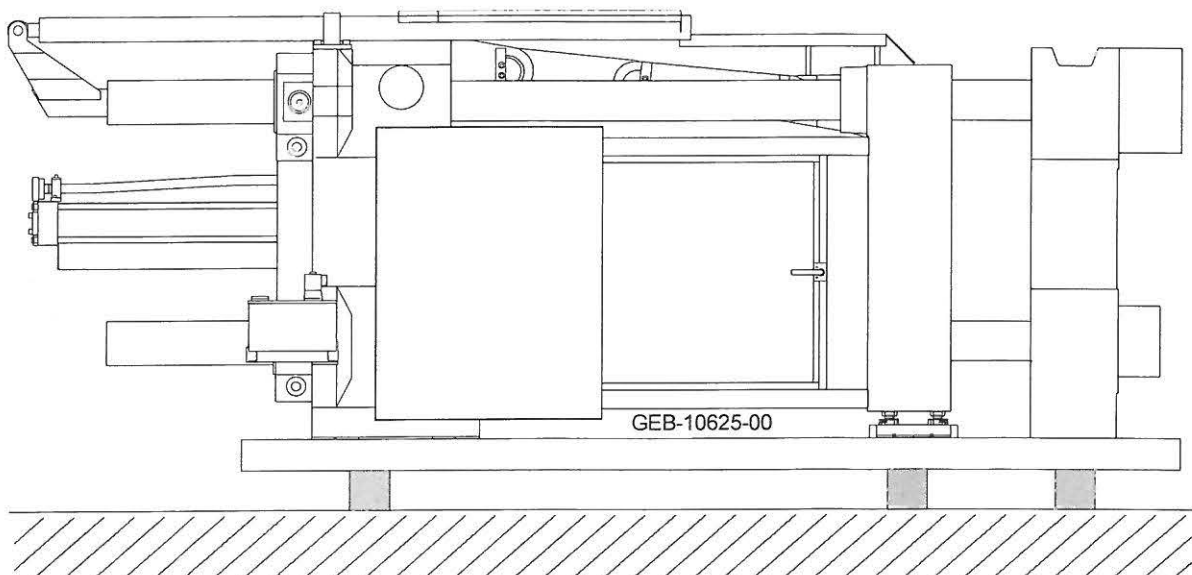

6.8 Weights and points of attachment

**DANGER!**

Check the lifting gear for its permissible loading capacity. Standing under suspended loads can be fatal.

Please take the weights and points of attachment from the enclosed instructions for lifting.

6.9 Instructions for lifting

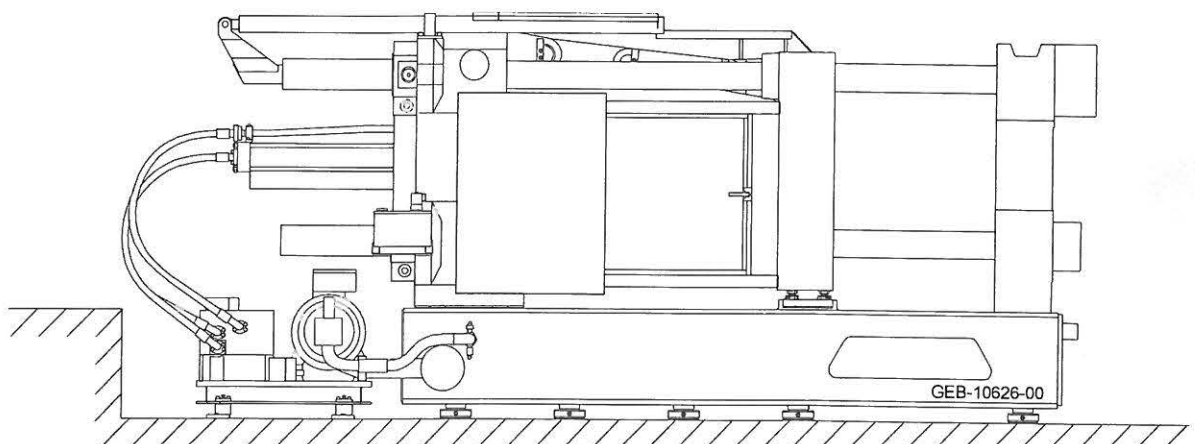
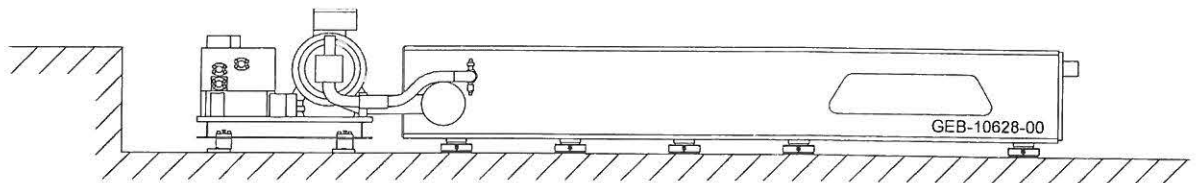
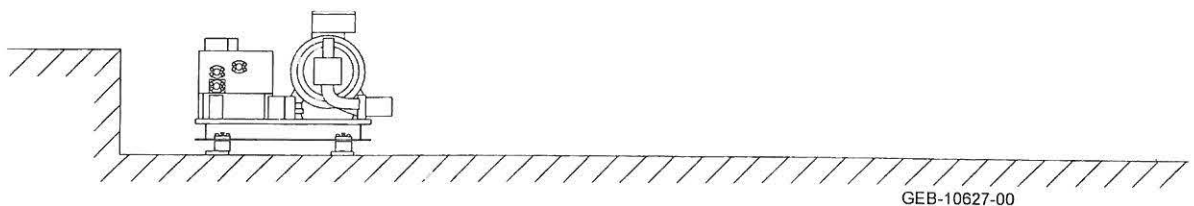

6.9.3 Closing unit with machine base

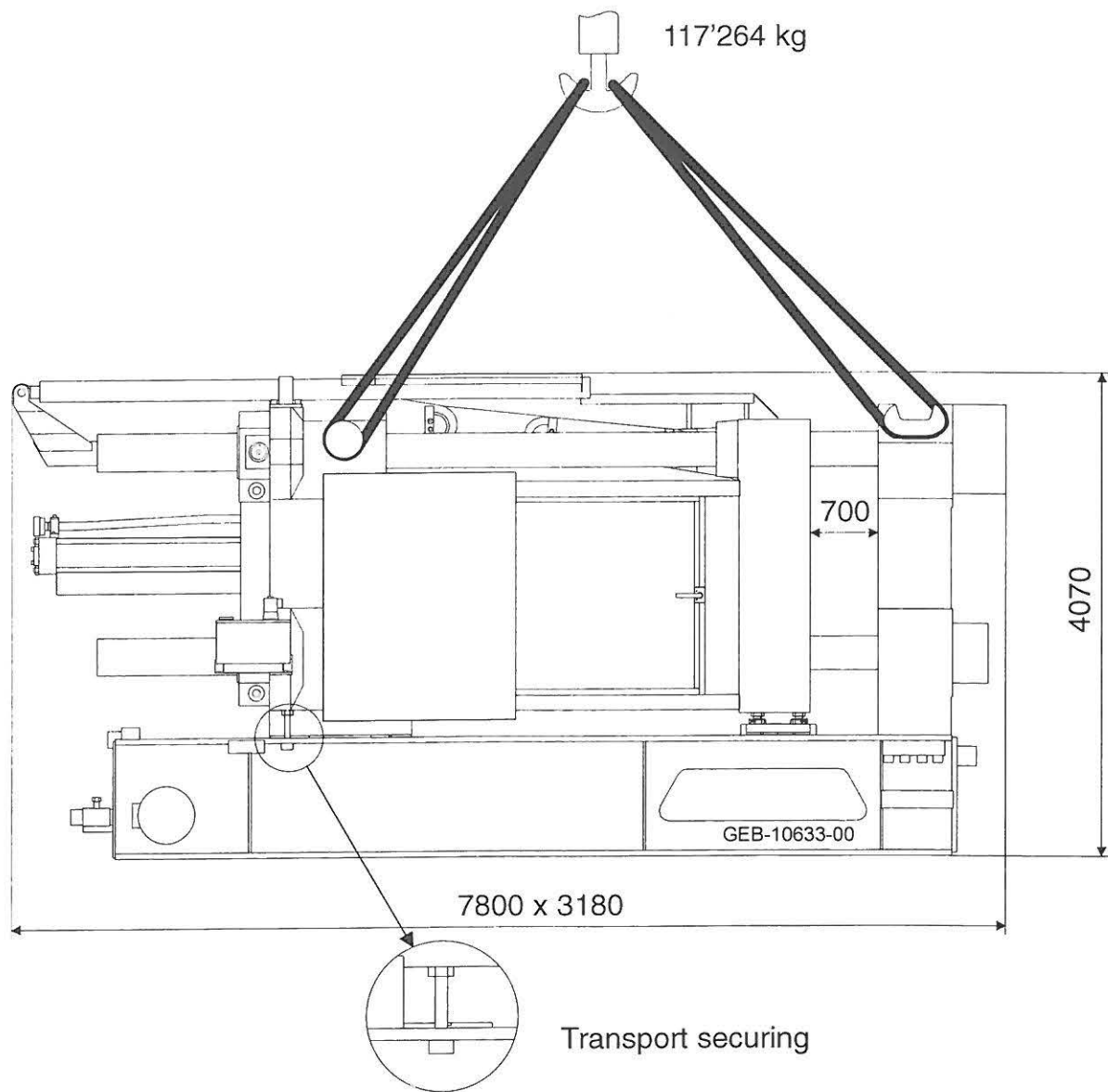

6.9.4 Drive unit

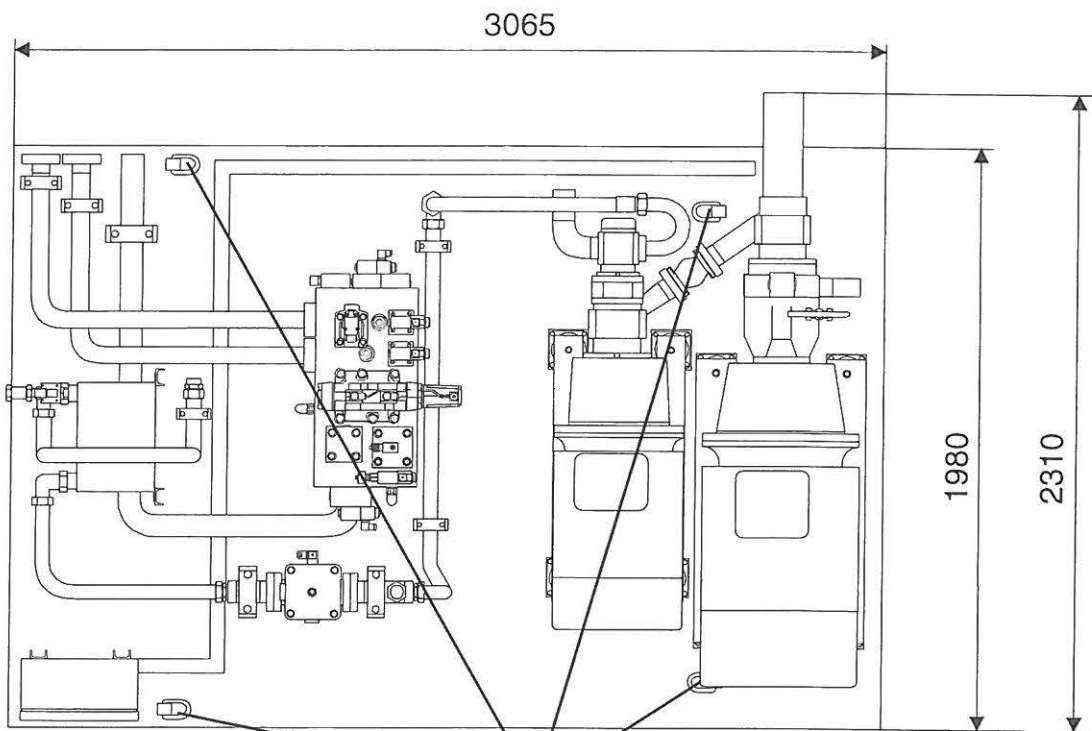
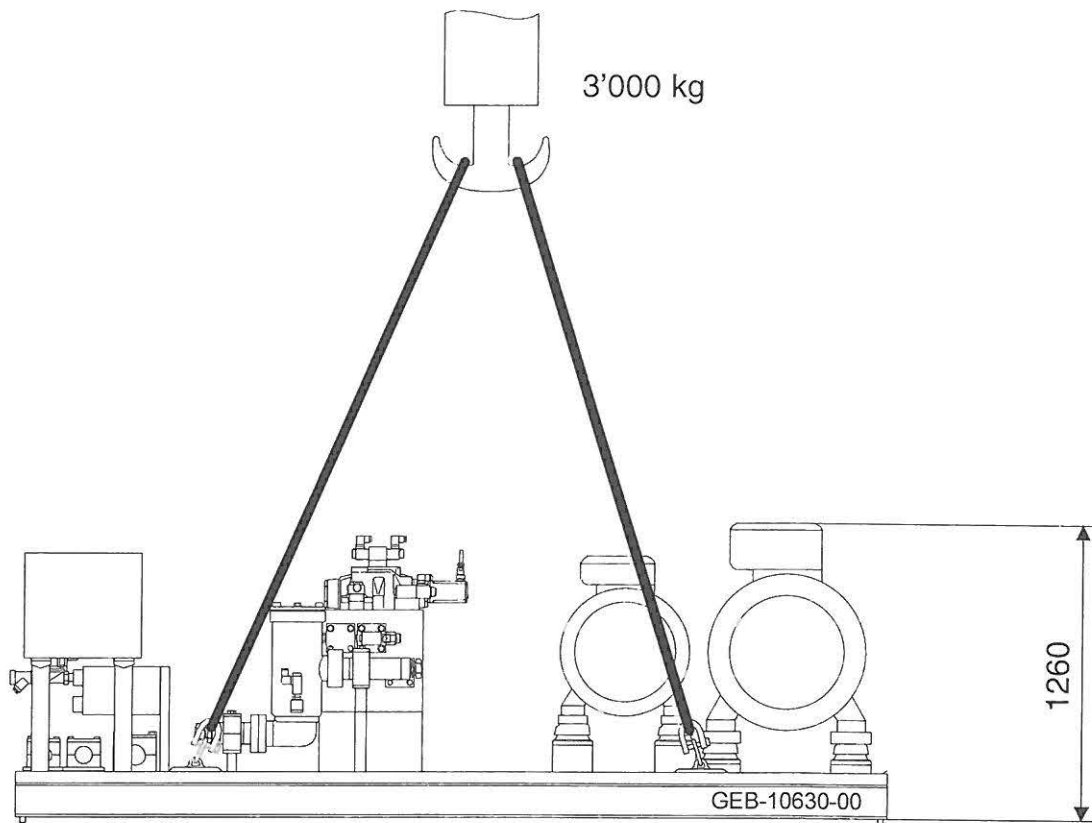

Attachment points

6.9.5 Injection unit

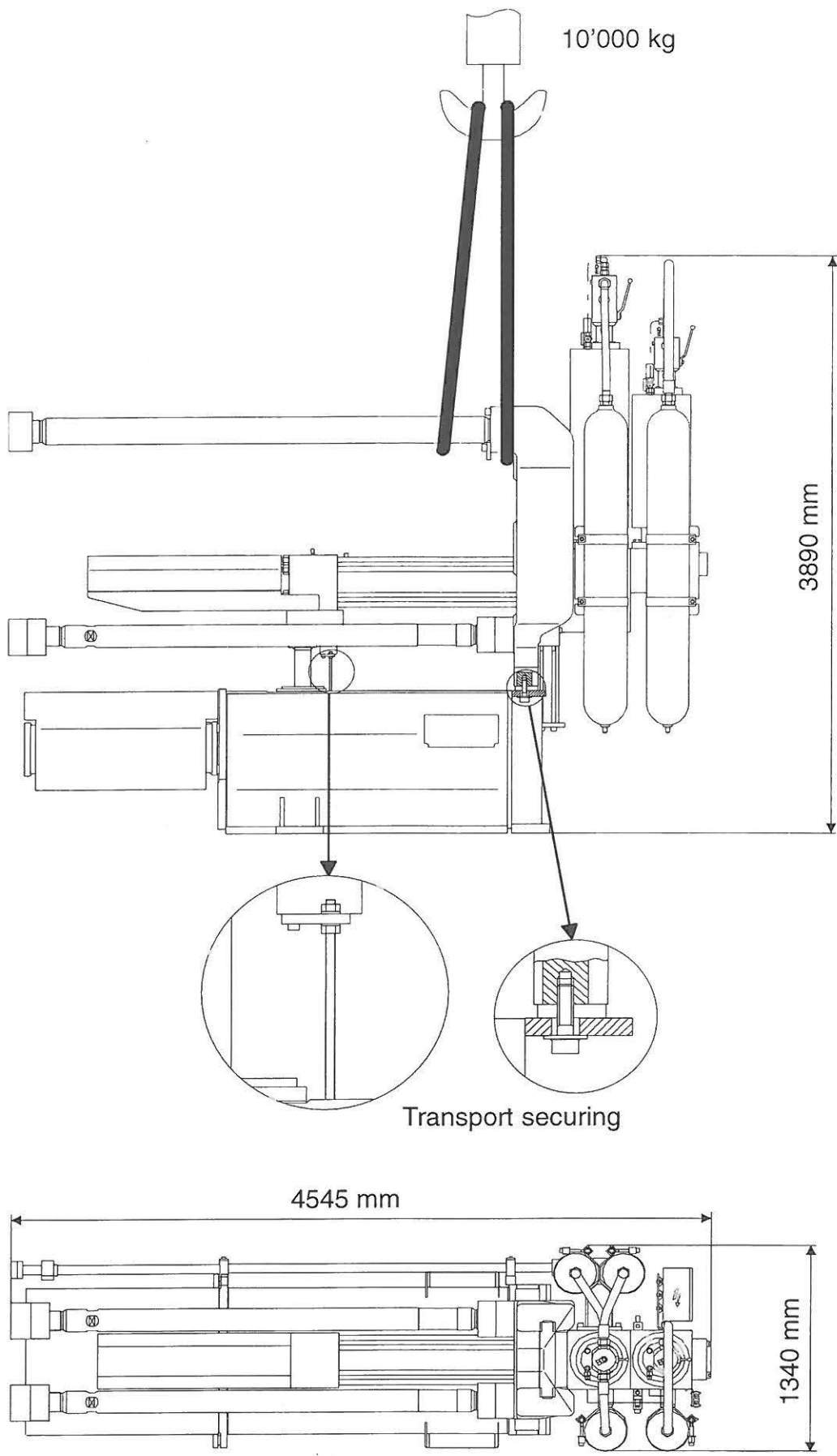

6.9.6 Control cabinet

